

Rapid
SINCE 1979

連續式染色試驗機（毛毛蟲系列）
CONTINUOUS DYEING MACHINE FOR LABORATORY.
(MMC SERIES)

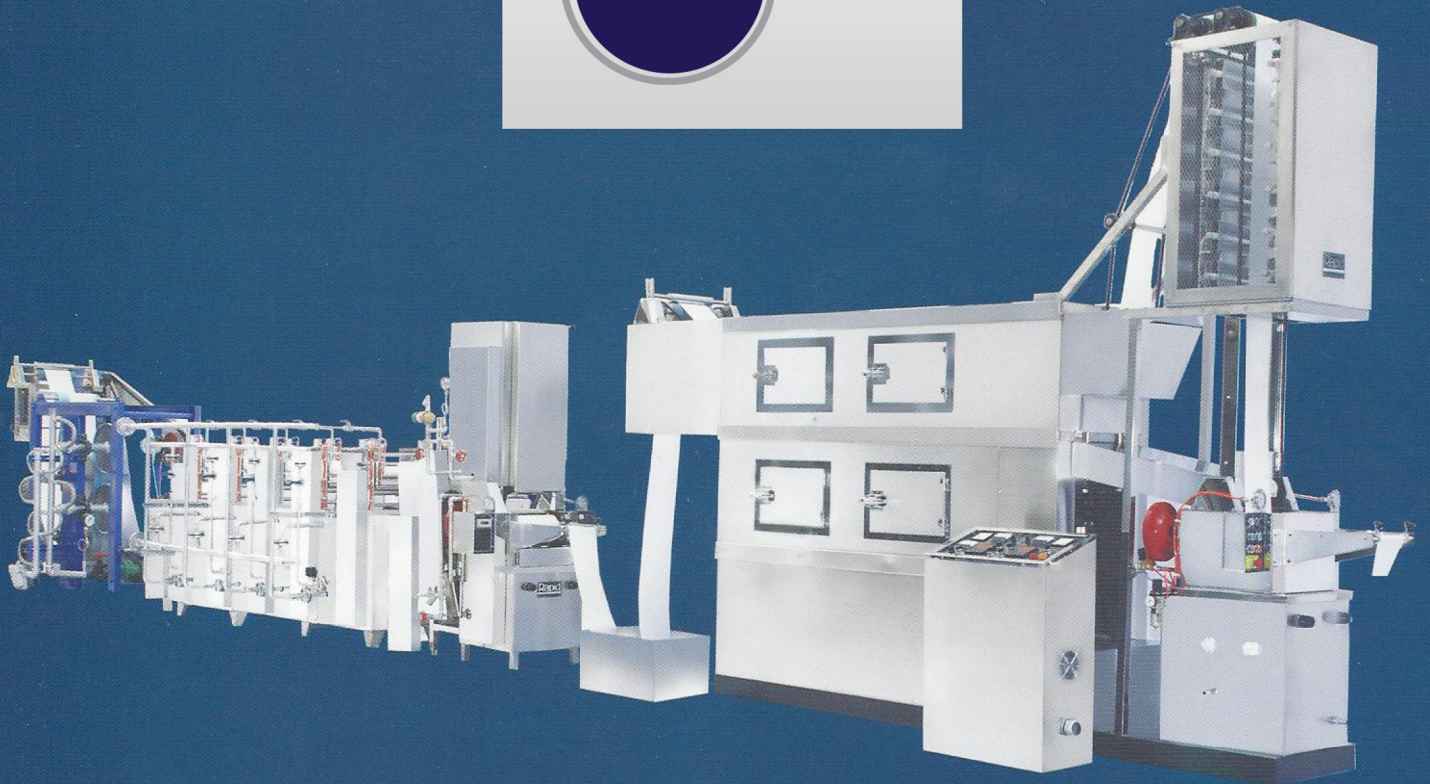

廈門瑞比精密機械有限公司
XIAMEN RAPID PRECISON MACHINERY CO.,TLD.

標準流程組合:

Example of standard range layout:



CD-4

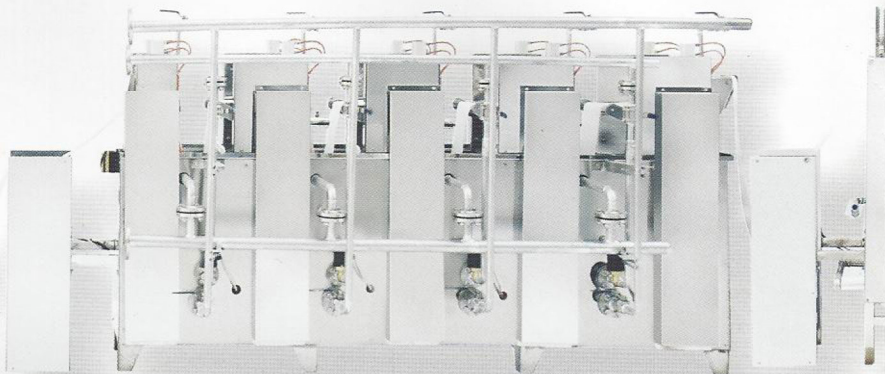

WJ-4

廈門瑞比公司基于長期在連續染色（軋染）方面的經驗，特別制造出 MMC（毛毛蟲）系列的化驗室連續式染色機，此機極適合制作車間大量生產用配方，而且擁有極精確的再現性，同時也是研究開發不可或缺的設備之一。

Xiamen RAPID (Formerly LABORTEX) gain from long term experience on continuous dyeing, to produce MMC series of Laboratory continuous dyeing and finishing machineries suitable for on-the -spot recipe evaluation as well as offering the most precise reproducibility. This MMC equipments also play an important role on Research and Development.

應用範圍:

本公司所制造的連續式染色試驗機（毛毛蟲系列）可廣泛應用用于100%棉，滌綸/棉 混紡的平織布，或各項織帶，拉鏈等的軋染染色工藝。

Application :

This machine MMC series are designed for carrying out all continuous dyeing and finishing process in Laboratory with 100% cotton, polyester/cotton blended material fabric. Also suitable for narrow fabric, such as ribbon, nylon tapes, zipper etc.

機器特點:

使用高質量不銹鋼板制成，防酸鹼腐蝕，美觀耐用，同時采用和車間生產機器相同的染色工藝流程，可獲得最高的再現性。主要流程如下：
染料軋液→紅外線預乾→熱風循環預烘110-130℃→熱熔培烘 200-220℃→化學藥液軋液→蒸氣烘箱處理→後處理（水洗，自洗，或還原，氧化等）→蒸氣式滾桶烘乾。

Machine Features :

All high class Stainless Steel made and Guide Cloth type Continuous Laboratory dyeing machine. Mainly processes :
Dye Padding → Infra-Red Pre-Heater → Intermediate Dryer → Thermosoling → Chemical Padding → Steaming → speed compensator → Multi Bath washing range → speed compensator → Drying by steam heating cylinders



連續式染色試驗機（毛毛蟲系列）型號：MMC-30-4

CONTINUOUS DYEING MACHINE FOR LABORATORY Model:MMC-30-4

技術規格：

連續式染色試驗機（毛毛蟲系列）主要是由以下本公司的4種產品組合而成，并使用張力補償器來控制速度，以達到連續作業的目的。

- 連續式壓吸熱固色機 （型號 PT-J）
- 連續式壓吸蒸染試驗機 （型號 PS-JS）
- 連續式小型水洗機 （型號 WJ-4）
- 蒸氣滾筒烘乾機 （型號 CD-4）

The detailed specification refer to individual catalog of each machine.

詳細規格可參考各別機台的目錄說明

Specification :

A combination unit for our 4 existing products, model PT-J, PS-JS, WJ-4, CD-4. Tension control and compensator is in the range.

1. LABORATORY THERMOSOL RANGE (MODEL. PT- J)
2. CONTINUOUS PAD-STEAM RANGE (MODEL PS-JS)
3. 4 BATHS LAB WASHING MACHINE (MODEL WJ - 4)
4. 4 CYLINDER DRYER (MODEL CD - 4)

其他系列組合：

Other Combination:

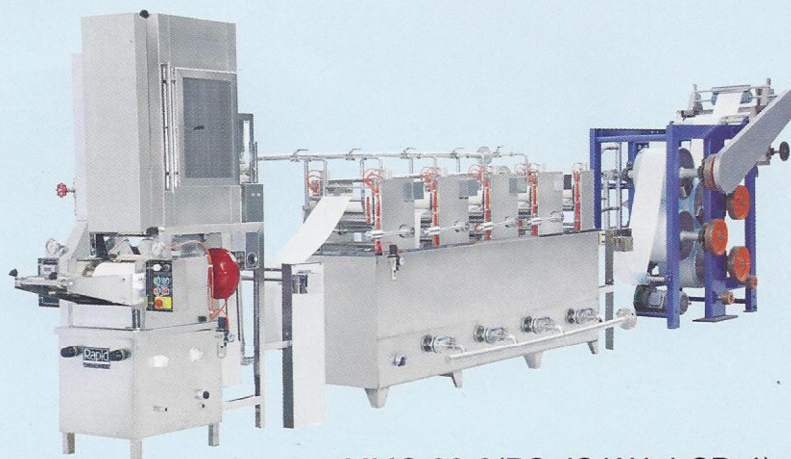

MMC-30-3(PS-JS,WJ-4,CD-4)

标准配置尺寸图:

Standard range layout with size indication:

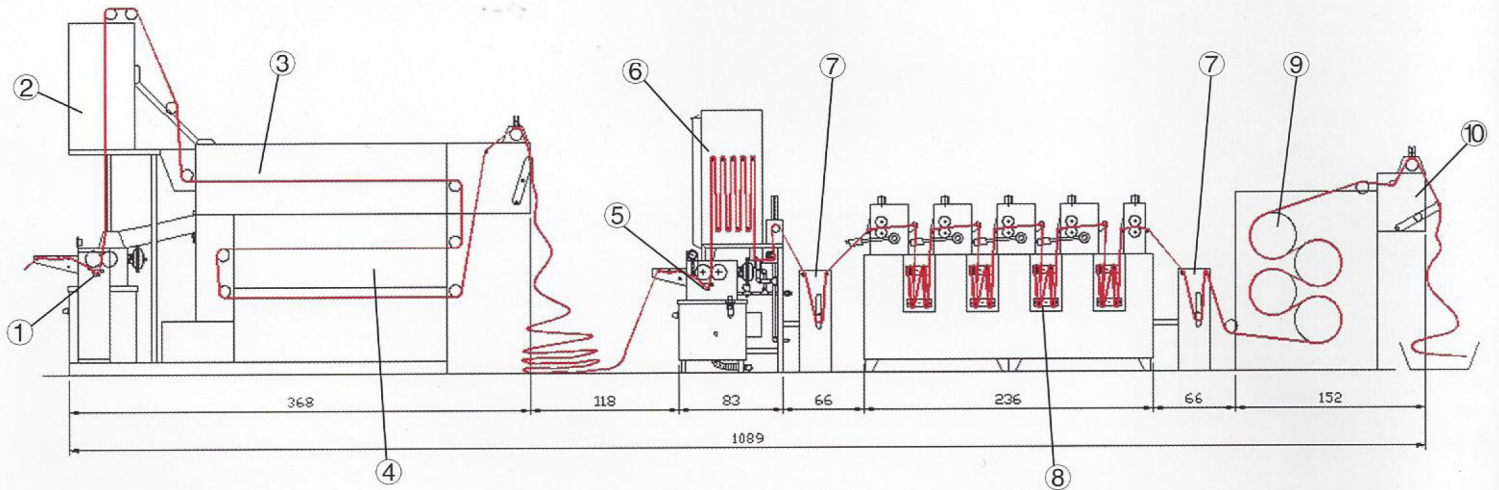

1. 染料軋液	Dye padding	6. 蒸氣烘箱	Steam chamber
2. 紅外線預乾	Infra red pre-dryer	7. 調速器	Speed Compensator
3. 熱風循環預烘	Electric heating pre-dryer	8. 水洗槽	Washing baths
4. 熱風循環培烘	Thermosol Chamber	9. 蒸氣滾桶烘乾	Dryer Cylinder
5. 化學液軋液	Chemical padding	10. 落布裝置	Take off device

型號指定方式:

Model designation:

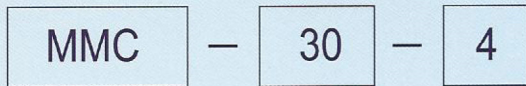

軋輪寬度 Width of roller

30 : 300 mm

60 : 600 mm

機器組合 Component of machine

4 components : PT-J, PS-JS, WJ-4, CD-4

3 components : PS-JS, WJ-4, CD-4

2 components : PS-JS, WJ-4

*水洗機最多可提供8個水洗槽

Washing unit with up to 8 wash baths

*其他規格可另行指定制作

Other specifications are available on request.



Laborteks Analitik ve Kalite Kontrol Test Cihazları San.Tic.Ltd.şti

İstoç 31.Ada No: 48/50 P.K : 34217Bağcılar / ISTANBUL

Tel : +90 212 623 00 00

Fax : +90 212 623 05 17

Gsm : +90 532 257 15 04

Web : www.trrapid.com

e-mail: apetek@laborteks.com.tr